

# VARIABLE AIR VOLUME CIRCULAR DAMPER

## e-VAV self-sufficient & connected

- The e-VAV is a variable air volume damper which enables:
- to manage the airflow of fresh air in offices, commercial buildings and classrooms.
  - to regulate the airflow and measure the indoor air quality with its integrated sensors (humidity, temperature and CO<sub>2</sub>).

The airflow can also be regulated by an external 0-10 V signal or a dry contact from a remote sensor (presence or CO<sub>2</sub> sensor).

e-VAV is energy self-sufficient and doesn't require any power wiring. It generates its own electricity thanks to its turbine operating by the air flow and its energy harvesting system. This energy is used to supply electricity to the damper and measure indoor air quality.



### VERSIONS

- e-VAV, variable air volume damper, energy self-sufficient
- e-VAV QAI, variable air volume damper with air quality sensor (CO<sub>2</sub>), energy self-sufficient
- e-SENSE, air quality sensor (CO<sub>2</sub>, HR, T°), energy self-sufficient
- Pack e-VAV QAI: made of one e-VAV QAI with CO<sub>2</sub> sensor for extract, one e-VAV for supply, and one specific master/slave wire

### CONSTRUCTION

	e-VAV			
	Ø125 mm	Ø160 mm	Ø200 mm	Ø250 mm
Casing	PC-ABS, certified M1		PC-ABS <i>M0 in option</i>	
Iris damper	PC-ABS, certified M1			
Airproofing membrane	Seal			
Connection	Male connection with EPDM seal			

### TECHNICAL SPECIFICATIONS

	e-VAV
Casing airtightness	Class C
Upstream/downstream airtightness	Not classified
Operating temperature	+0°C to +45°C
Operating relative humidity	0...80 % RH (non-condensing)
Wire control (room sensors)	0..10 V signal or ON/OFF switch
Communication	LoRaWan

# VARIABLE AIR VOLUME CIRCULAR DAMPER

e·VAV self-sufficient & connected

## DIMENSIONS

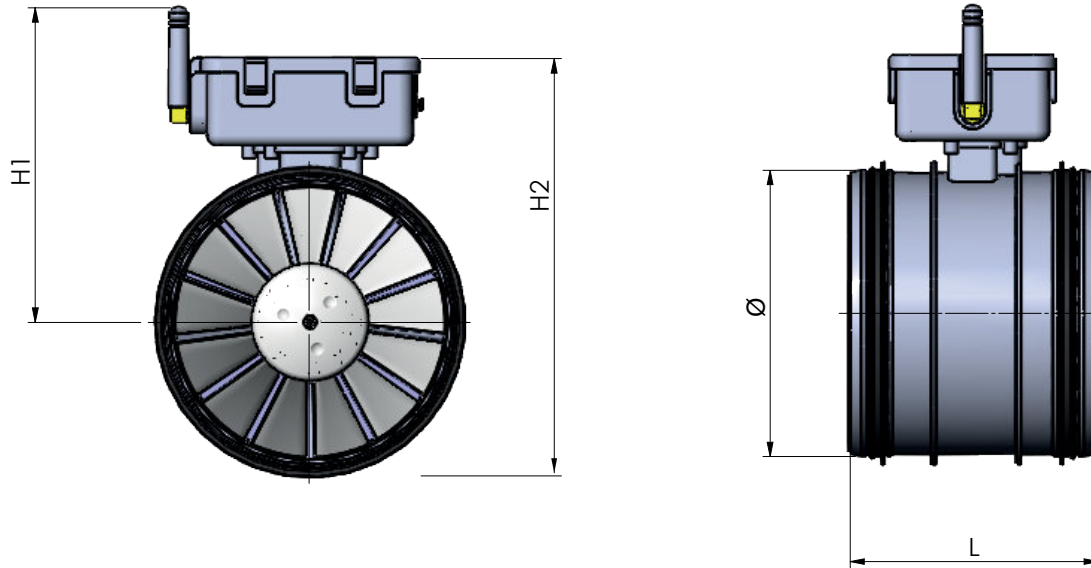

	Ø125 mm	Ø160 mm	Ø200 mm	Ø250 mm
Length in mm	105	105	200	200
Height H1 in mm	130	156	173	198
Height H2 in mm	172	190	248	298
Weight in kg	0.45	0.70	2	4

## AIR MANAGEMENT SPECIFICATION

	e·VAV			
	Ø125 mm	Ø160 mm	Ø200 mm	Ø250 mm
Airflow range min	30 m <sup>3</sup> /h	40 m <sup>3</sup> /h	120 m <sup>3</sup> /h	180 m <sup>3</sup> /h
Airflow range max	220 m <sup>3</sup> /h	400 m <sup>3</sup> /h	600 m <sup>3</sup> /h	1100 m <sup>3</sup> /h
Pressure range min - max	10 Pa - 250 Pa			

The advised airflow range is from 0.5 m/s to 5 m/s

# VARIABLE AIR VOLUME CIRCULAR DAMPER

**e-VAV** self-sufficient & connected

## ACOUSTIC PERFORMANCES WITH A 50 Pa PRESSURE LOSS

	Air velocity m/s	Airflow m <sup>3</sup> /h	63 Hz	125 Hz	250 Hz	500 Hz	1000 Hz	2000 Hz	4000 Hz	8000 Hz	Global Lw (dBA)
			Air-regenerated, sound power level Lw								
Ø125 mm	1	44	55	44	40	35	24	17	17	18	35
	3	133	56	51	53	48	41	32	25	19	48
	5	221	53	51	55	50	48	39	32	22	53
Ø160 mm	1	72	48	48	40	32	21	16	16	18	36
	3	217	53	53	50	43	37	29	25	19	45
	5	362	58	57	54	49	46	43	34	23	52
Ø200 mm	1	113	53	47	39	34	29	30	24	18	38
	3	339	60	60	53	49	45	41	32	21	52
	5	565	63	65	64	62	57	54	45	36	63
Ø250 mm	1	177	54	48	40	32	24	21	19	18	36
	3	530	60	60	56	50	45	40	32	21	53
	5	884	64	64	66	62	60	57	50	36	65

## ACOUSTIC PERFORMANCES WITH A 150 Pa PRESSURE LOSS

	Air velocity m/s	Airflow m <sup>3</sup> /h	63 Hz	125 Hz	250 Hz	500 Hz	1000 Hz	2000 Hz	4000 Hz	8000 Hz	Global Lw (dBA)
			Air-regenerated, sound power level Lw								
Ø125 mm	1	44	60	48	43	42	35	32	34	25	43
	3	133	59	57	67	56	47	39	35	29	58
	5	221	60	59	61	55	53	46	43	36	58
Ø160 mm	1	72	52	53	45	40	34	33	34	29	44
	3	217	57	58	61	53	45	40	35	28	54
	5	362	62	63	62	55	50	48	41	34	58
Ø200 mm	1	113	57	53	50	48	47	49	44	38	54
	3	339	64	66	59	55	51	52	51	42	59
	5	565	66	70	66	62	58	57	54	47	65
Ø250 mm	1	177	59	55	49	44	41	4	57	51	61
	3	530	65	66	60	52	48	57	60	57	65
	5	884	69	69	68	62	60	57	54	58	66

Acoustic performances with a 100 Pa pressure loss, on request

# VARIABLE AIR VOLUME CIRCULAR DAMPER

**e· VAV** self-sufficient & connected

## TECHNICAL SPECIFICATIONS SENSORS AND COMMUNICATION

Relative Humidity and Temperature sensor	RH operating range	0 to 80 % (non-condensing)
	Accuracy	± 3 %
	Operating temperature T°	0 to 45 °C
	Accuracy	± 1 °C
	Type	Low power MEMS sensor
CO <sub>2</sub> sensor	CO <sub>2</sub> operating range	0 to 2000 ppm
	Accuracy	± 50 ppm
	Type	NDIR low power
Communication RF	Protocol	LoRaWan
	Frequency band	868 GHz

## DESCRIPTION

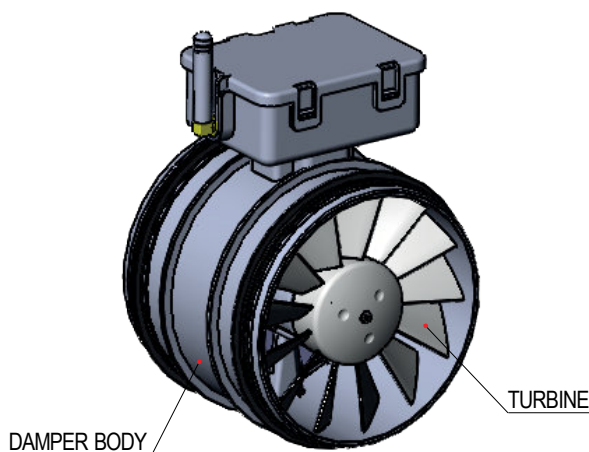

The external box has 1 plug:

- One RJ12 to connect a CO<sub>2</sub> sensor or a presence detector

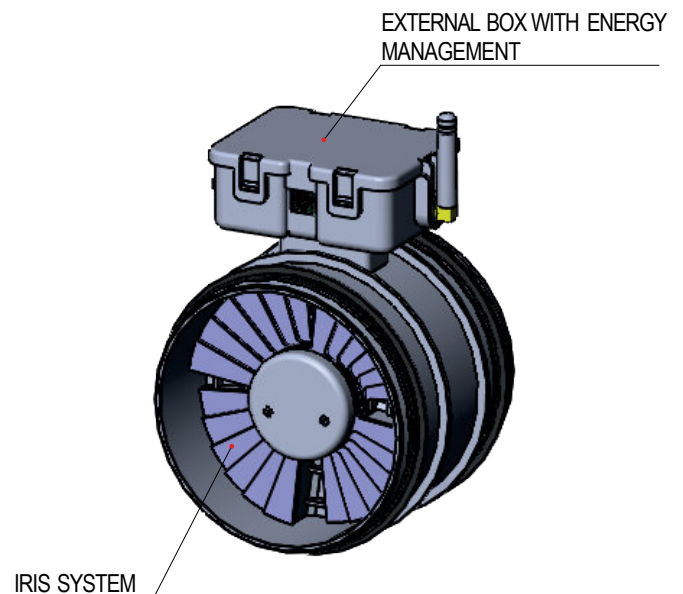

# VARIABLE AIR VOLUME CIRCULAR DAMPER

e-VAV self-sufficient & connected

## OPERATING PRINCIPLE

Supply or exhaust air controlled by a room CO<sub>2</sub> sensor with an e-VAV-S(S=Standard)

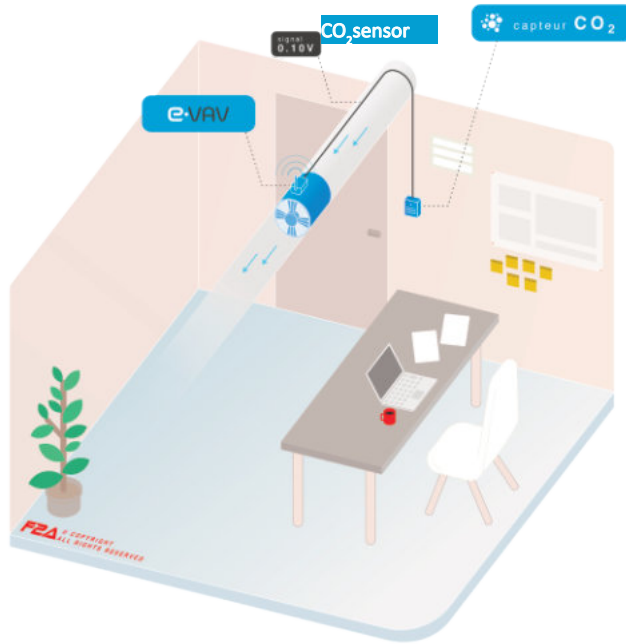

The damper is controlled by a 0..10 V signal from a room CO<sub>2</sub> sensor which itself measures in real time the CO<sub>2</sub> concentration and sends a 0..10 V signal to the damper to adapt the airflow rate.

The damper is factory set. The remote sensor can be supplied with 24 V by an external source.

The CO<sub>2</sub> sensor can be replaced by a presence detector.

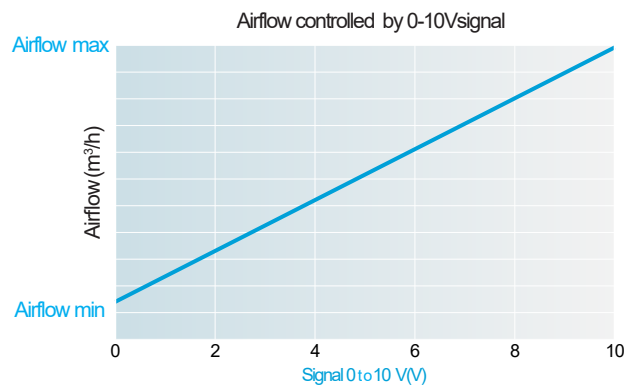
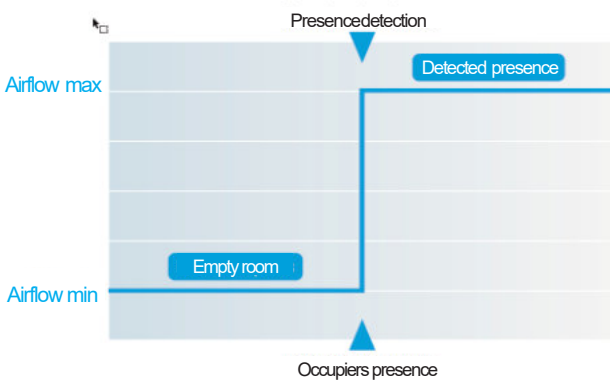

# VARIABLE AIR VOLUME CIRCULAR DAMPER

e-VAV self-sufficient & connected

## Wiring diagram

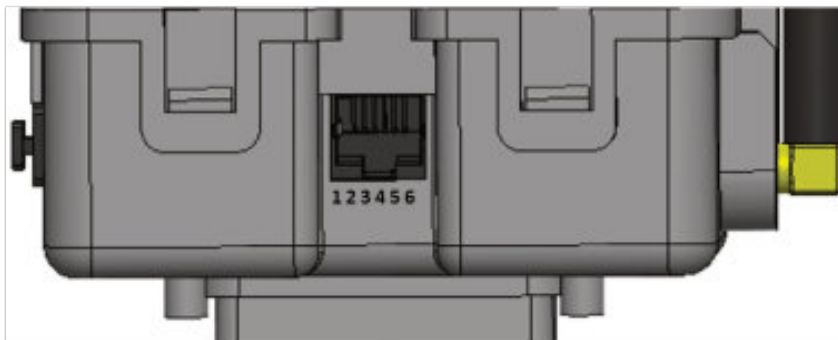
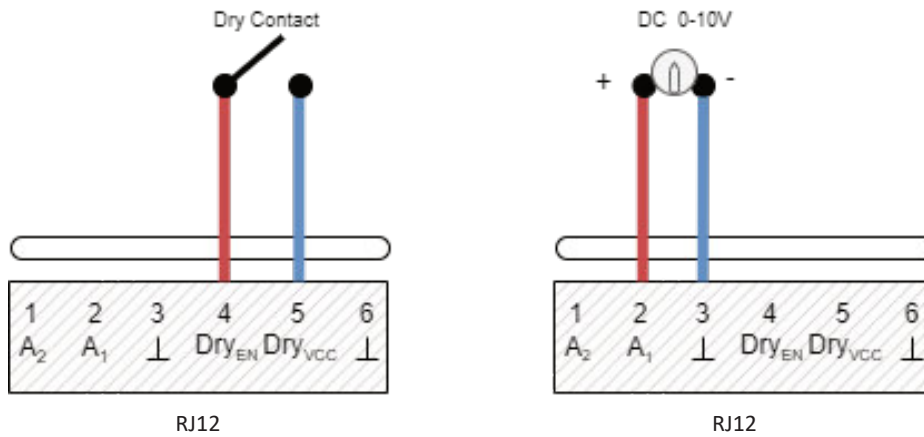

## Equipment list:

- 1 e-VAV
- 1 CO<sub>2</sub> room sensor 24 V
- 1 power transformer 230 V-24 V
- In option: presence detector.

# VARIABLE AIR VOLUME CIRCULAR DAMPER

e·VAV self-sufficient & connected

Exhaust air controlled by an e-VAVQAI with integrated CO<sub>2</sub> sensor



The e-VAV QAI damper in the exhaust is controlled by the CO<sub>2</sub> measured by its integrated sensor. The damper is factory set with minimum and maximum airflow and CO<sub>2</sub> values. No connection needed

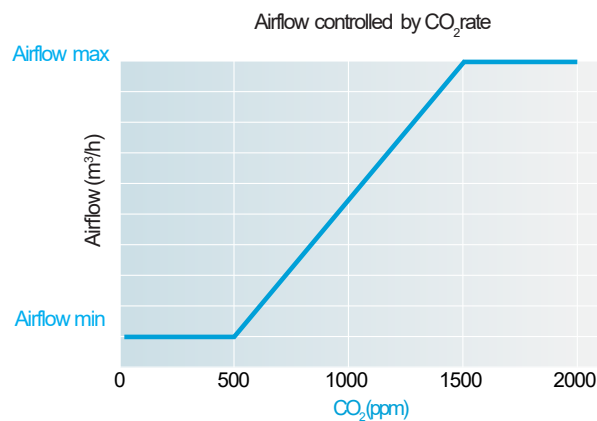

# VARIABLE AIR VOLUME CIRCULAR DAMPER

e·VAV self-sufficient & connected

Exhaust air controlled by an e·VAV QAI with integrated CO<sub>2</sub> sensor at the exhaust and one slave e·VAV at the supply

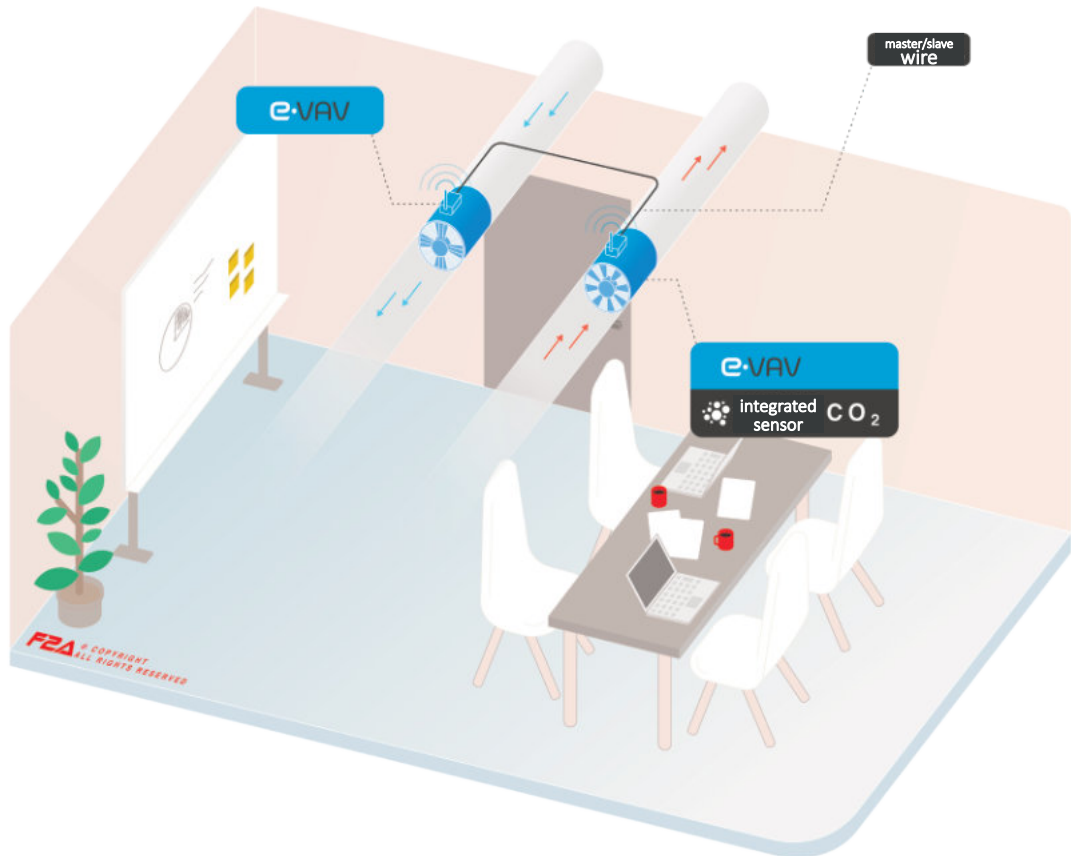

The e·VAV QAI damper in the exhaust is controlled by the CO<sub>2</sub> measured from its integrated sensor. It is factory set with minimum and maximum airflow and CO<sub>2</sub> values.

The e·VAV damper at the supply is on slave mode controlled by the e·VAV QAI master. The signal is transmitted via a specific wire provided.

Pack e·VAV QAI equipment list:

- 1 e·VAV QAI at the exhaust
- 1 e·VAV at the supply
- 1 master/slavewire

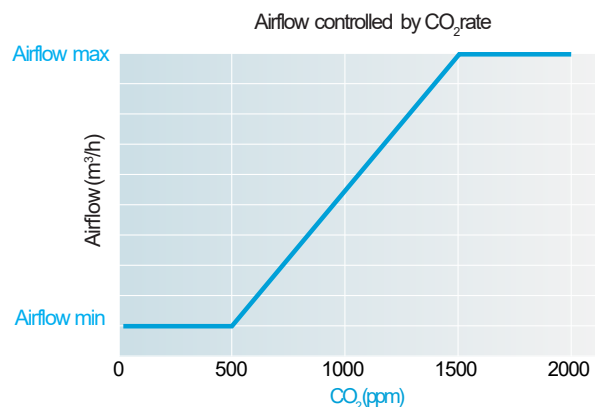

# VARIABLE AIR VOLUME CIRCULAR DAMPER

e·VAV self-sufficient & connected

## Wiring diagram



1/ Select the RJ45 connection  
On the lateral side of the electrical box



2/ Plug the cable delivered with the e-VAV



3/ Check the cable is well connected then do  
the same with the other e-VAV



4/ The 2 e-VAV are now connected  
in master/slave mode

## INSTALLATION

Always install the e·VAV with the airflow facing the turbine.

The damper fits between two sections of ductwork thanks to EPDM seals. No screw is needed.

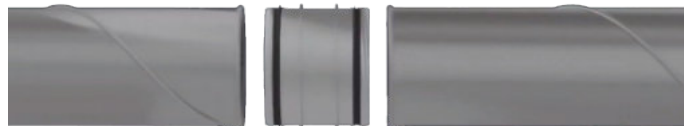

## COMMISSIONING

The e·VAV needs an air flow to be activated. Start the AHU and wait for the e·VAV to start the regulation. The start-up time is a maximum of 60 minutes and an average of 40 minutes.

After 60 min, the e-VAV starts to reach the target according to the signal it receives: dry contact, 0-10V or CO<sub>2</sub>.

LoRa commissioning: all products are labelled with their LoRa identifier

<b>N° Article :</b>	EVAVD125-S	<b>Designation :</b>	EVAV D125 HRT		
<b>Dev EUI :</b>	XX-XX-XX-XX-XX-XX-XX-XX-XX				
<b>Label :</b>	eVAV T5	<b>Building :</b>	n°1	<b>Place :</b>	R5
<b>Regulation :</b>	0-10 V				
<b>Airflow min :</b>	40	<b>Value min :</b>	0 V		
<b>Airflow max :</b>	220	<b>Value max :</b>	10 V		

# VARIABLE AIR VOLUME CIRCULAR DAMPER

e·VAV self-sufficient & connected

## COMMISSIONING WITH REMOTE CONTROL

For more information, ask for the dedicated technical documentation of the e-VAV remote control. You will find all the information for modifying the airflow and the other parameters.



### «Main» Menu

Turn on the remote control, plug the RJ45 and press "Connect e·VAV"

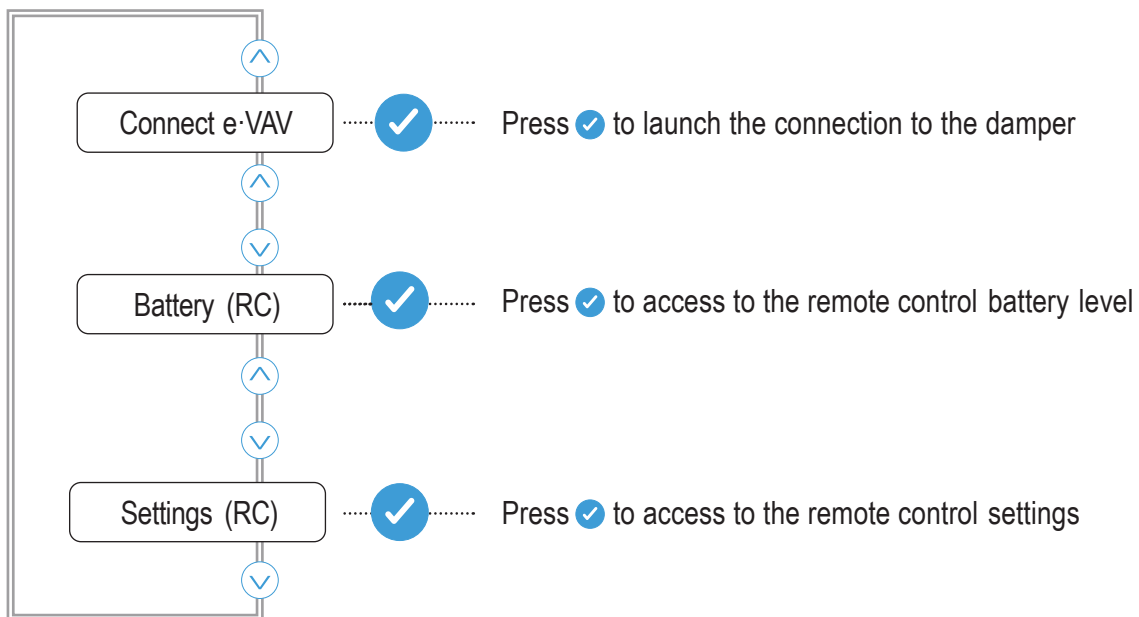

# VARIABLE AIR VOLUME CIRCULAR DAMPER

e·VAV self-sufficient & connected

## «Connect e-VAV» Menu

Select the appropriate menu according to your needs

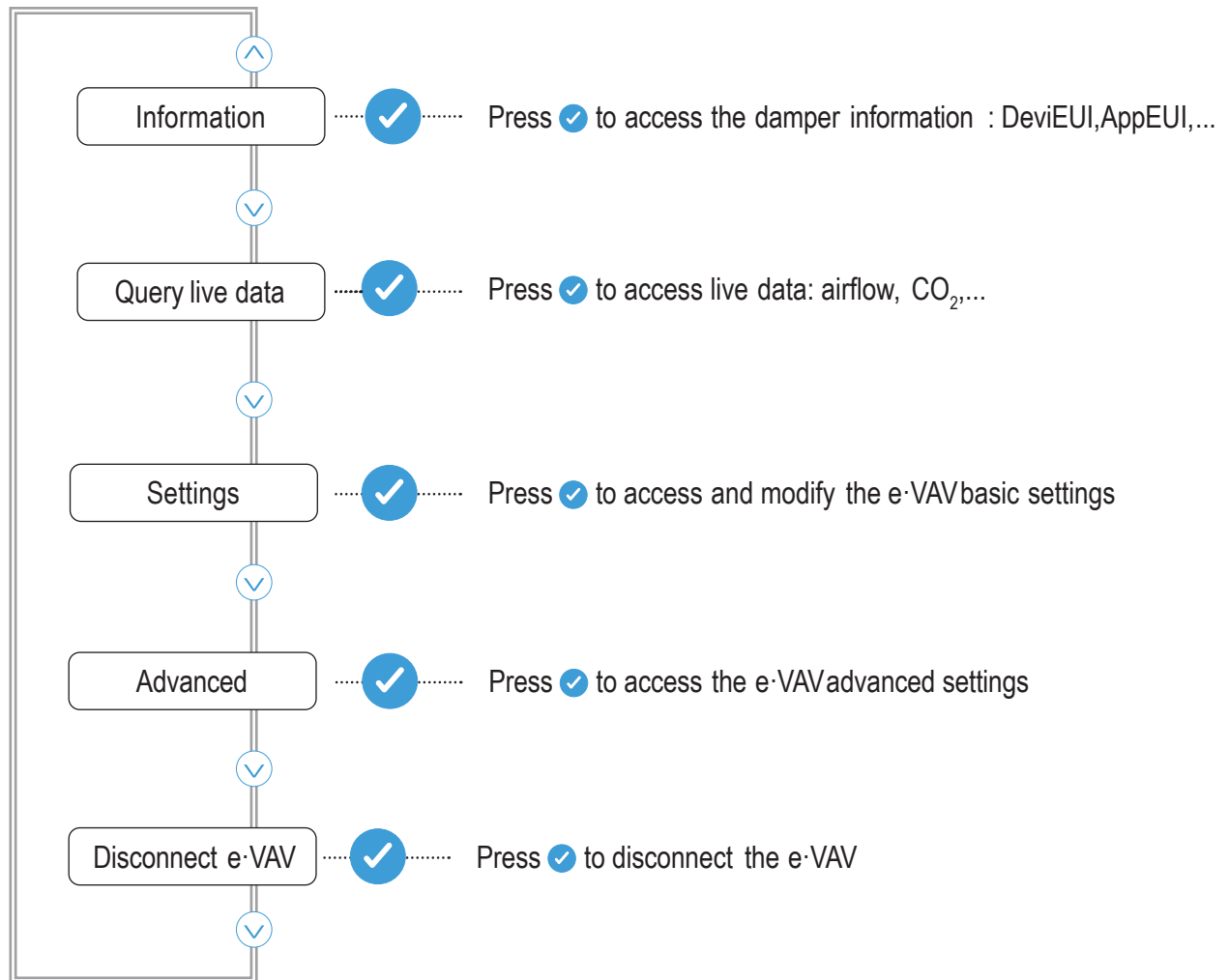

The remote control allows you to modify all the e-VAV parameters : airflow, CO<sub>2</sub> level, .....

In order to modify parameters, the remote control has to be wirely plug into e-vav.

# VARIABLE AIR VOLUME CIRCULAR DAMPER

e-VAV self-sufficient & connected

## MONITOR YOUR INDOOR AIR QUALITY AND ACT ON YOUR SYSTEM WITH SI-MO

The e-VAV communicates with LoRaWAN protocol. It allows you to manage all parameters remotely. With the integrated sensors, you can monitor the indoor air quality (CO<sub>2</sub>), the comfort and all the airflows in your buildings. You can check the damper efficiency, optimize the consumption and the costs.

You can act to change the configuration of the damper remotely controlled through the LoRa network. It allows you to adjust your ventilation system to optimize it during all the building life cycle.

The SI-MO solution enables also the use of LoRaWAN CO<sub>2</sub> sensor or occupancy sensor to control directly the eVAV damper. So, the whole installation is wireless and without cabling.

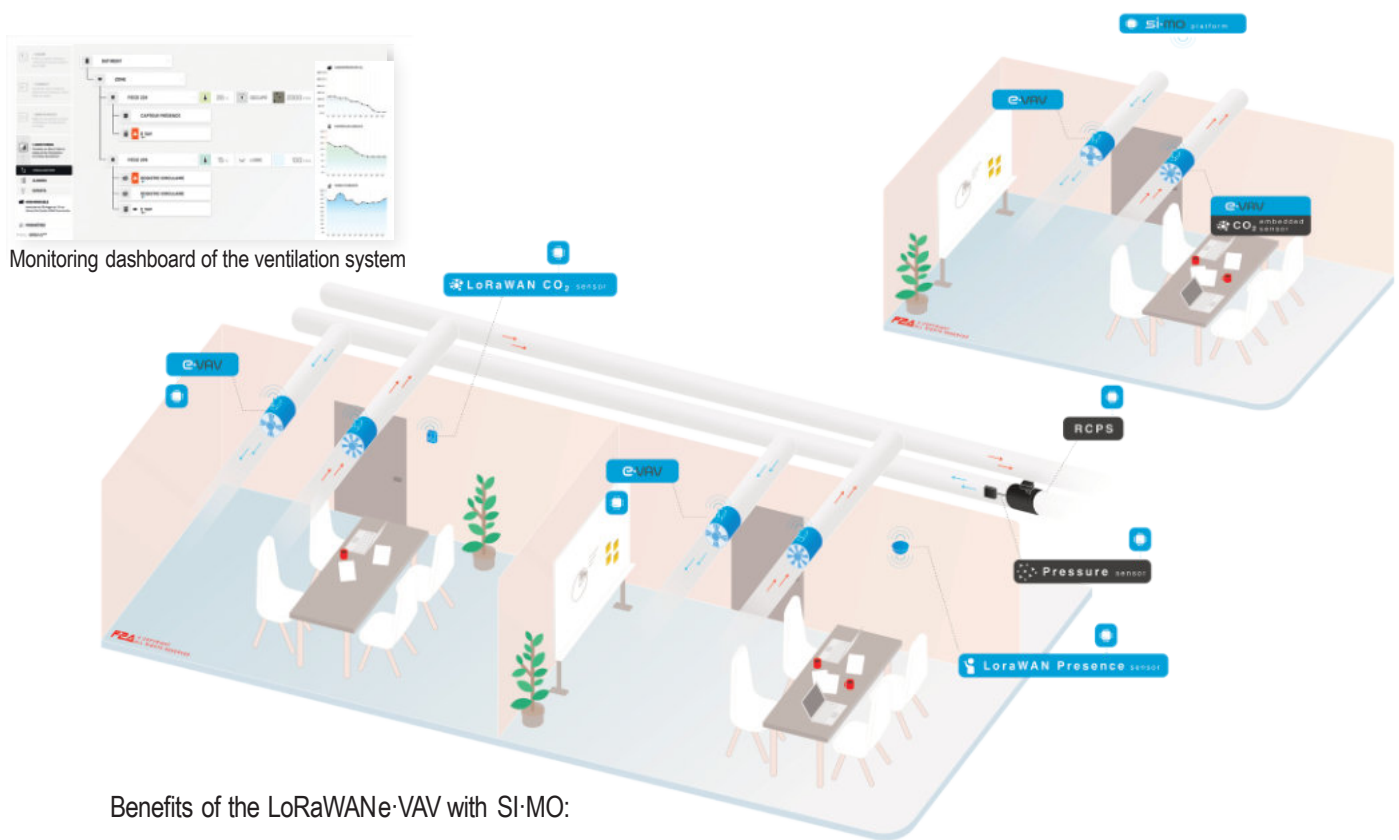

Benefits of the LoRaWAN e-VAV with SI-MO:

- Easy solution to add an Indoor Air Quality system
- Monitor the Indoor Air Quality during the whole lifetime of the building
- Act and control your variable air volume damper remotely
- Detect and solve issues without human intervention

Product list:

- e-VAV: self-powered variable air volume damper
- Gateways: box to receive and send LoRa information
- LoRaWAN sensors, CO<sub>2</sub> or occupancy
- SI-MO controller : vav and e-VAV controller
- Dashboard: a ready-to-roll solution to monitor all the dampers, embedded into the SI-MO controller



The e-VAV can also interact with other IoT products in the building, controlled by another platform using the LoRaWAN communication protocol.