



**CHARACTERISTICS:**  
Multifunctional plenum kit for DLF / DLN linear slot diffusers.

**CONSTRUCTION:**  
Made of galvanized steel (PDLCCmodel) with polyethylene outer insulation sp. 6 mm (PDLCCImodel) and removable plastic material spigots.

**UTILIZATION:**  
Simultaneously for single installation and for lines of continuity realization.

**FIXING:**  
Assembly of the plenum to the diffuser by means of inclined brackets (CVL) and screws all included in the Kit.

**PACKING:**  
Single Packed with Protective Nylon.

MODELLO - MODEL	L	Z	ØD	STACCHI SPIGOTS	STAFFE INCLINATE BRACKETS CVL	PREZZO PRICES *	PEZZI PER BANCALE PIECES FOR PALLET (1200 x 800)
	mm	mm	mm	nr	nr	A	nr
PDLCCI- 1F - 1000	1000	66	156	1	2	71,81	38
PDLCCI- 1F - 1500	1500	66	156	2	2	95,01	38
PDLCCI- 2F - 1000	1000	105	156	2	2	86,04	24
PDLCCI- 2F - 1500	1500	105	156	3	2	112,21	24
PDLCCI- 3F - 1000	1000	144	196	2	2	94,43	19
PDLCCI- 3F - 1500	1500	144	196	3	2	123,72	19
PDLCCI- 4F - 1000	1000	181	196	2	2	102,30	15
PDLCCI- 4F - 1500	1500	181	196	3	2	134,15	15

#### DISEGNI - DRAWINGS

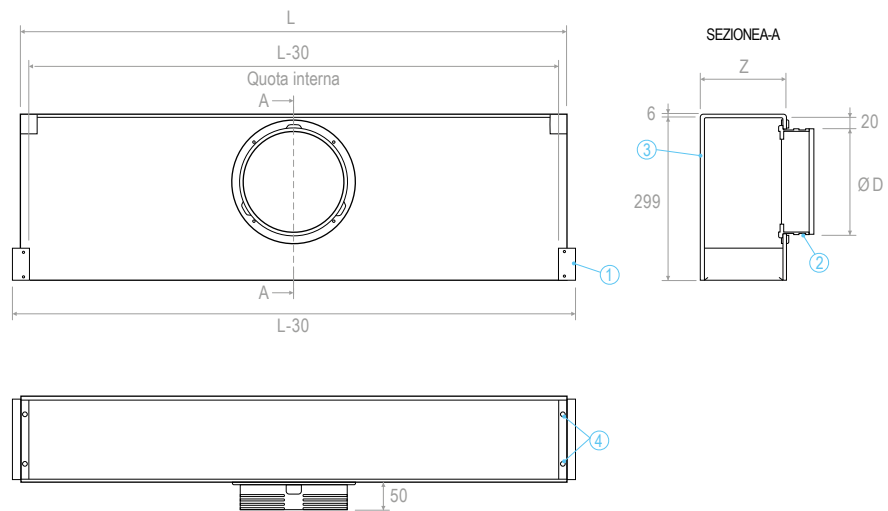

- ⇒ Tappo laterale da rimuovere in caso di continuità - Side cap to be removed in case of continuity
- ⊕ Manicotto in plastica fornito in dotazione con montaggio a cura del cliente - Plastic spigot supplied with customized mounting
- ⊖ Isolamento esterno in polietilene sp. 6 mm - Polyethylene outer insulation thickness 6 mm
- ⊕ fori Ø9 per fissaggio - Holes Ø9 for mounting

**PHASE 1:**

Force the head part on the side that will form the line of continuity along the pre-cut line (Fig. 1) until the bottom of the head is released (Fig. 2 / Fig. 3). Store the part of the header named A. Installation of the spigot on the plenum (fig. 4). Cut with cutter and remove the end of the insulation so that you can install A (fig.5).

**PHASE 2:**

Join the two plenums by ensuring the flatness and the precise coincidence between the pieces (Fig. 6). Install the top part of the junction of the two plenums with the previously removed A part and secure it with self-tapping screws supplied with the Kit (fig.6 / fig.7). Fix the plenum boxes internally with the screws supplied with the kit (fig.8).

fig 1

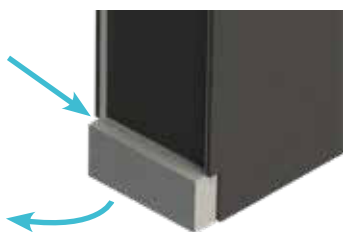

fig 2



fig 3

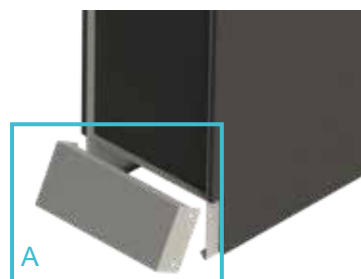

fig 4

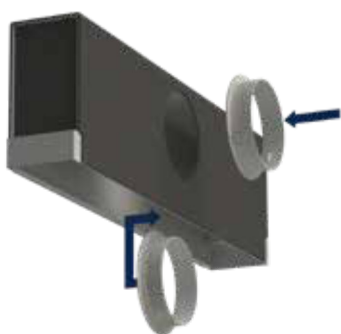

fig 5



fig 6

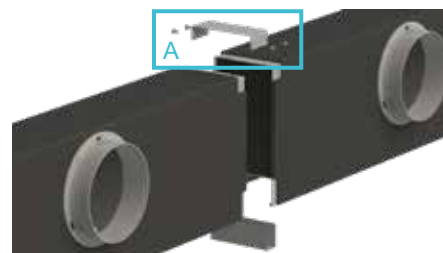

fig 7



fig 8

