

CHARACTERISTICS:
 Floor grilles composed BY horizontal fixed bars with 12,5 mm pitch, with frame.

CONSTRUCTION:
 Anodized aluminium.

UTILIZATION:
 For floor installation and for air intake or delivery.

FIXING:
 Fixing by using screws.

ACCESSORIES:

- Calibration damper made of galvanized steel and fins with opposite movement.

		
BxH	GRPZ	SCZ
mm	A	A
300x100	30,53	12,27
300x150	42,15	13,88
400x100	38,97	13,06
400x150	53,60	16,35
400x200	68,39	19,59
500x100	47,32	15,91
500x150	65,21	18,76
500x200	83,03	22,87
500x300	118,52	28,60
600x100	55,75	17,99
600x150	76,68	21,23
600x200	103,05	26,15
600x300	130,56	31,03
600x400	169,38	37,60
800x100	72,67	23,24
800x150	99,60	26,93
800x200	134,14	31,86
800x300	168,96	37,60
800x400	219,10	45,74
1000x100	89,52	28,39
1000x150	122,54	32,14
1000x200	164,95	35,11
1000x300	207,36	44,93
1000x400	268,71	53,91

ACCESSORI - ACCESSORIES:

SCZ: Serranda di taratura ad alette con movimento contrapposto - Opposed blade damper

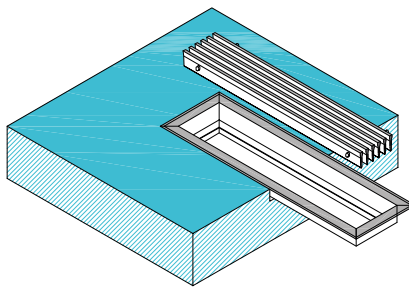
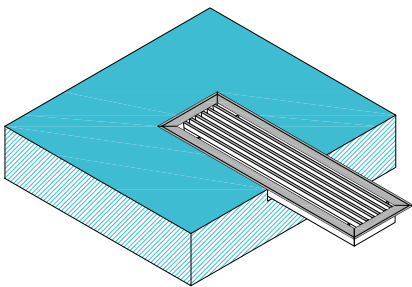
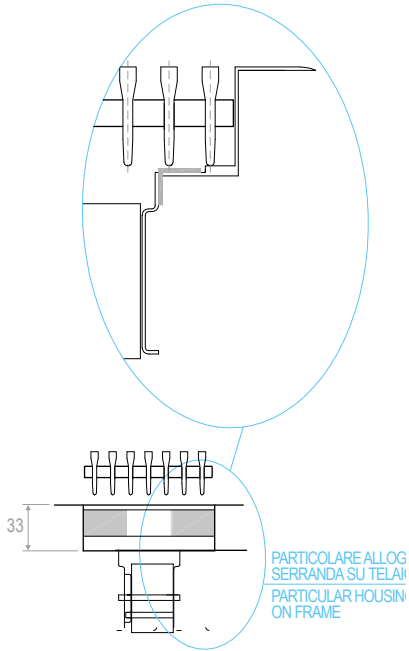
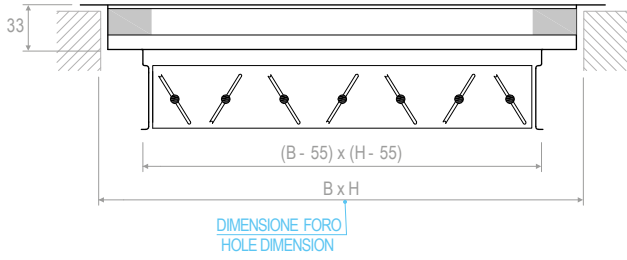
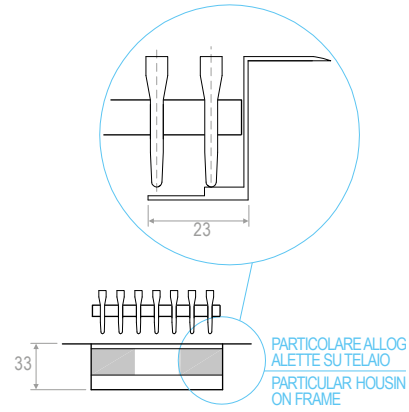
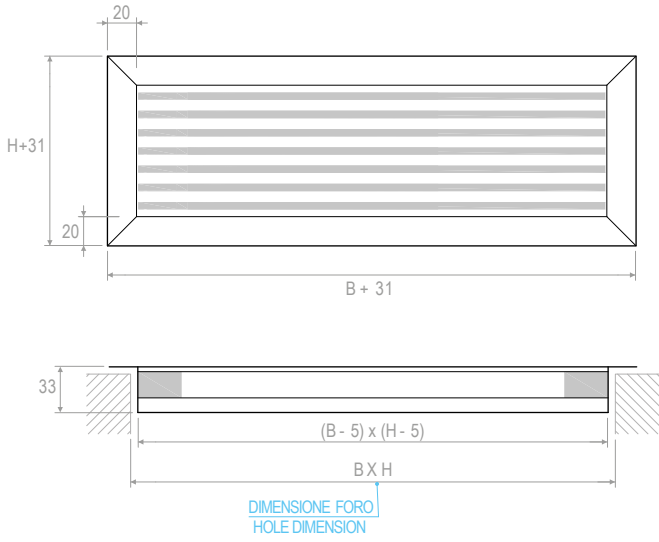

GRI

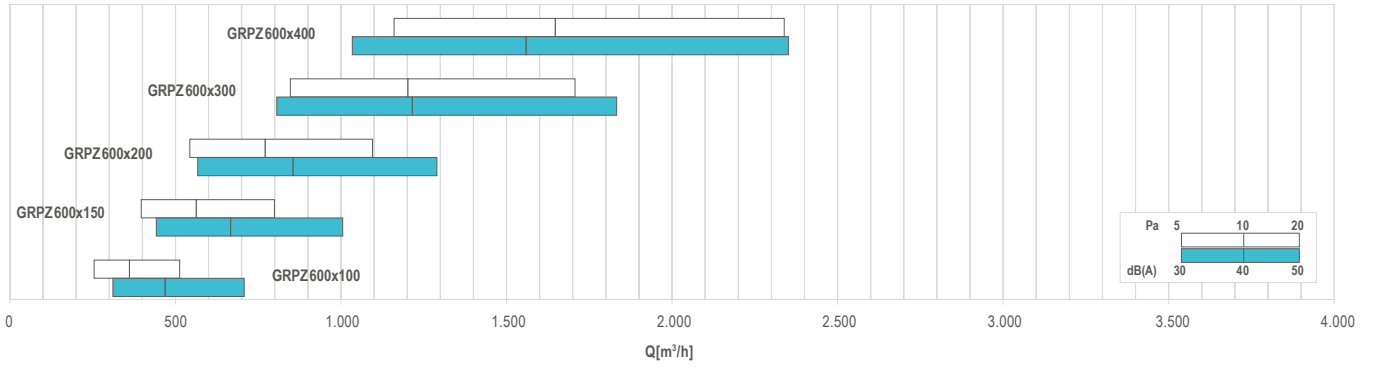

Modello - Model	A _s [m ²]	Q [m ³ /h]		L _{WA} [dB(A)]		Y (0,25) [m]		Dp [Pa]	
		min	max	min	max	min	max	min	max
GRPZ300x100	0,0126	120	240	21	38	2,2	4,9	5	20
GRPZ400x100	0,0172	160	330	22	40	2,6	5,9	5	20
GRPZ500x100	0,0220	210	420	24	41	3,2	6,7	5	20
GRPZ600x100	0,0268	250	510	25	42	3,5	7,4	5	20
GRPZ800x100	0,0368	350	700	27	44	4,2	8,8	5	20
GRPZ1000x100	0,0470	450	900	28	45	4,9	10,0	5	20
GRPZ300x150	0,0196	190	370	24	40	3,1	6,3	5	20
GRPZ400x150	0,0268	250	510	25	42	3,5	7,6	5	20
GRPZ500x150	0,0343	320	650	26	43	4,1	8,6	5	20
GRPZ600x150	0,0418	400	800	28	44	4,7	9,6	5	20
GRPZ800x150	0,0573	540	1100	29	46	5,4	11,3	5	20
GRPZ1000x150	0,0732	690	1400	30	47	6,2	12,7	5	20
GRPZ400x200	0,0368	350	700	27	44	4,4	9,1	5	20
GRPZ500x200	0,0470	450	900	28	45	5,0	10,3	5	20
GRPZ600x200	0,0573	540	1100	29	46	5,5	11,4	5	20
GRPZ800x200	0,0785	740	1500	30	48	6,5	13,3	5	20
GRPZ1000x200	0,1003	950	1920	32	49	7,4	15,1	5	20
GRPZ500x300	0,0732	690	1400	30	47	6,4	13,1	5	20
GRPZ600x300	0,0893	850	1710	31	48	7,1	14,5	5	20
GRPZ800x300	0,1224	1160	2340	33	50	8,3	16,9	5	20
GRPZ1000x300	0,1563	1480	2990	34	51	9,4	19,1	5	20
GRPZ600x400	0,1224	1160	2340	33	50	8,4	17,1	5	20
GRPZ800x400	0,1677	1590	3200	34	51	9,8	20,0	5	20
GRPZ1000x400	0,2141	2030	4090	36	53	11,1	22,5	5	20

